

# Service Manual

## Air Conditioner

**CS-E9DKEW CU-E9DKE**  
**CS-E12DKEW CU-E12DKE**

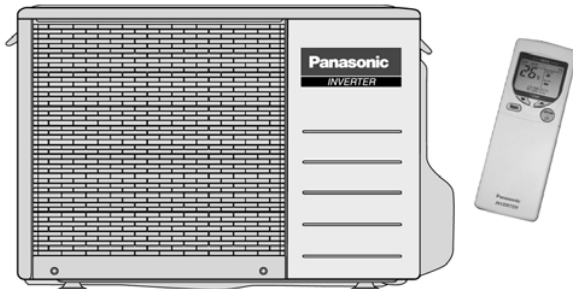

### ⚠ WARNING

This service information is designed for experienced repair technicians only and is not designed for use by the general public. It does not contain warnings or cautions to advise non-technical individuals of potential dangers in attempting to service a product. Products powered by electricity should be serviced or repaired only by experienced professional technicians. Any attempt to service or repair the product or products dealt with in this service information by anyone else could result in serious injury or death.

### ⚠ PRECAUTION OF LOW TEMPERATURE

In order to avoid frostbite, be assured of no refrigerant leakage during the installation or repairing of refrigeration circuit.

## CONTENTS

	Page		Page
<b>1 Features</b> .....	2	8.2. Protection Control Features .....	35
<b>2 Functions</b> .....	3	<b>9 Operating Instructions</b> .....	44
2.1. Remote Control .....	3	<b>10 Installation Instructions</b> .....	50
2.2. Indoor Unit .....	4	10.1. Safety Precautions .....	50
2.3. Outdoor Unit .....	6	10.2. Indoor Unit .....	53
<b>3 Product Specifications</b> .....	7	10.3. Outdoor Unit .....	57
3.1. CS-E9DKEW CU-E9DKE .....	7	<b>11 Installation And Servicing Air Conditioner Using R410A</b> .....	61
3.2. CS-E12DKEW CU-E12DKE .....	9	11.1. Outline .....	61
<b>4 Dimensions</b> .....	11	11.2. Tools For Installing/Servicing Refrigerant Piping .....	62
4.1. Indoor Unit & Remote Control .....	11	11.3. Refrigerant Piping Work .....	66
4.2. Outdoor Unit .....	12	11.4. Installation, Transferring, Servicing .....	68
<b>5 Refrigeration Cycle Diagram</b> .....	13	<b>12 Servicing Information</b> .....	72
<b>6 Block Diagram</b> .....	14	12.1. Troubleshooting .....	72
<b>7 Wiring Diagram</b> .....	15	12.2. Breakdown Self Diagnosis Function .....	74
<b>8 Operation Details</b> .....	16	12.3. Remote Control .....	76
8.1. Basic Function .....	16		

# Panasonic®

© 2004 Panasonic HA Air-Conditioning (M) Sdn Bhd (11969-T). All rights reserved. Unauthorized copying and distribution is a violation of law.

## 3 Product Specifications

### 3.1. CS-E9DKEW CU-E9DKE

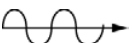
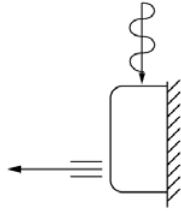
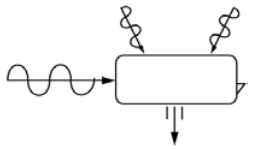
		Unit	CS-E9DKEW	CU-E9DKE
Cooling Capacity		kW kcal/h BTU/h	2.6 (0.80 - 3.00) 2,240 (690 - 2,580) 8,870 (2,050 - 10,200)	
Heating Capacity		kW kcal/h BTU/h	3.6 (0.80 - 5.00) 3,100 (690 - 4,300) 12,300 (2,050 - 17,100)	
Moisture Removal		l/h Pint/h	1.6 (3.4)	
Power Source (Phase, Voltage, Cycle)		ø V Hz	Single 230 50	
Airflow Method		OUTLET  INTAKE 	SIDE VIEW 	TOP VIEW 
Air Volume	Lo	m <sup>3</sup> /min (cfm)	Cooling; 6.2 (220) Heating; 6.6 (230)	—
	Me	m <sup>3</sup> /min (cfm)	Cooling; 7.9 (280) Heating; 8.6 (300)	—
	Hi	m <sup>3</sup> /min (cfm)	Cooling; 9.6 (340) Heating; 10.5 (370)	Cooling; 29.8 (1,050)
	SHi	m <sup>3</sup> /min (cfm)	Cooling; 9.9 (350) Heating; 10.8 (380)	—
Noise Level		dB (A)	Cooling; High 39, Low 26 Heating; High 40, Low 27	Cooling; 46 Heating; 47
		Power level dB	Cooling; High 50 Heating; High 51	Cooling; High 59 Heating; High 60
Electrical Data	Input	W	Cooling; 600 (175 - 780) Heating; 845 (165 - 1,360)	
	Running Current	A	Cooling; 2.9 Heating; 4.0	
	EER	W/W (kcal/hw), BTU/hw	Cooling; 4.33 (3.73), 14.8	
	COP	W/W (kcal/hw), BTU/hw	Heating; 4.26 (3.67), 14.6	
	Starting Current	A	4.0	
Piping Connection Port (Flare piping)		inch inch	G ; Half Union 3/8" L ; Half Union 1/4"	G ; 3-way valve 3/8" L ; 2-way valve 1/4"
Pipe Size (Flare piping)		inch inch	G (gas side) ; 3/8" L (liquid side) ; 1/4"	G (gas side) ; 3/8" L (liquid side) ; 1/4"
Drain Hose	Inner diameter	mm	12	
	Length	m	0.65	

		Unit	CS-E9DKEW	CU-E9DKE	
Power Cord Length			—	—	
Number of core-wire			—	—	
Dimensions	Height	inch (mm)	11 - 1/32 (280)	21 - 1/4 (540)	
	Width	inch (mm)	31 - 15/32 (799)	30 - 23/32 (780)	
	Depth	inch (mm)	7 - 7/32 (183)	11 - 3/8 (289)	
Net Weight		lb (kg)	20 (9.0)	82 (37)	
Compressor	Type		—	Hermetic Rotary	
	Motor Type		—	Brushless (6-pole)	
	Rated Output	W	—	700	
Air Circulation	Type		Cross-flow Fan	Propeller Fan	
	Material		ASG20k1	P.P	
	Motor Type		Transistor (8-poles)	Induction (6-poles)	
	Input	W	—	61.3	
	Rate Output	W	30	28	
	Fan Speed	Lo (Cool/Heat)	rpm	820/880	—
		Me (Cool/Heat)	rpm	1,050/1,140	—
		Hi (Cool/Heat)	rpm	1,280/1,400	770
SHi (Cool/Heat)		rpm	1,320/1,440	—	
Heat Exchanger	Description		Evaporator	Condenser	
	Tube material		Copper	Copper	
	Fin material		Aluminium (Pre Coat)	Aluminium	
	Fin Type		Slit Fin	Corrugated Fin	
	Row / Stage		(Plate fin configuration, forced draft)		
	FPI		2 / 15	2 / 24	
	Size (W × H × L)	mm	610 × 315 × 25.4	718.4 × 504 × 36.4 689.8	
Refrigerant Control Device			—	Capillary Tube	
Refrigeration Oil		(cm <sup>3</sup> )	—	RB68A (320)	
Refrigerant (R410A)		g (oz)	—	965 (34.1)	
Thermostat			Electronic Control	—	
Protection Device			Electronic Control	Electronic Control	
Capillary Tube	Length	mm	—	C1, C2 ; 950, C3 ; 411	
	Flow Rate	l/min	—	C1, C2 ; 4.1, C3 ; 18.8	
	Inner Diameter	mm	—	C1, C2 ; 1.1, C3 ; 1.7	
Air Filter	Material		P.P.	—	
	Style		Honeycomb	—	
Fan Motor Capacitor		μF, VAC	—	2.0 μF, 440 VAC	
Compressor Capacitor		μF, VAC	—	65 μF, 350 VAC	

- Specifications are subject to change without notice for further improvement.

### 3.2. CS-E12DKEW CU-E12DKE

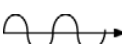
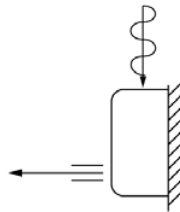
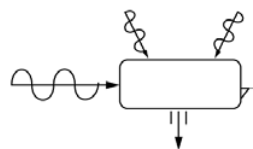
		Unit	CS-E12DKEW	CU-E12DKE
Cooling Capacity		kW kcal/h BTU/h	3.50 (0.80 - 4.00) 3,010 (690 - 3,440) 11,950 (2,730 - 13,600)	
Heating Capacity		kW kcal/h BTU/h	4.80 (0.80 - 6.50) 4,130 (690 - 5,590) 16,400 (2,730 - 22,200)	
Moisture Removal		l/h Pint/h	2.0 (4.2)	
Power Source (Phase, Voltage, Cycle)		ø V Hz	Single 230 50	
Airflow Method		OUTLET  INTAKE 	SIDE VIEW 	TOP VIEW 
Air Volume	Lo	m <sup>3</sup> /min (cfm)	Cooling; 6.9 (240) Heating; 8.1 (290)	—
	Me	m <sup>3</sup> /min (cfm)	Cooling; 8.8 (310) Heating; 9.7 (340)	—
	Hi	m <sup>3</sup> /min (cfm)	Cooling; 10.7 (380) Heating; 11.2 (400)	Cooling; 31.0 (1,090)
	SHi	m <sup>3</sup> /min (cfm)	Cooling; 11.0 (390) Heating; 11.6 (410)	—
Noise Level		dB (A)	Cooling; High 42, Low 29 Heating; High 42, Low 33	Cooling; 48 Heating; 50
		Power level dB	Cooling; High 53 Heating; High 53	Cooling; High 61 Heating; High 63
Electrical Data	Input	W	Cooling; 965 (185 - 1,200) Heating; 1,260 (175 - 1,890)	
	Running Current	A	Cooling; 4.5 Heating; 5.8	
	EER	W/W (kcal/hw), BTU/hw	Cooling; 3.63 (3.12), 12.4	
	COP	W/W (kcal/hw), BTU/hw	Heating; 3.81 (3.28), 13.0	
	Starting Current	A	5.8	
Piping Connection Port (Flare piping)		inch inch	G ; Half Union 1/2" L ; Half Union 1/4"	G ; 3-way valve 1/2" L ; 2-way valve 1/4"
Pipe Size (Flare piping)		inch inch	G (gas side) ; 1/2" L (liquid side) ; 1/4"	G (gas side) ; 1/2" L (liquid side) ; 1/4"
Drain Hose	Inner diameter	mm	12	—
	Length	m	0.65	—
Power Cord Length			—	—
Number of core-wire			—	—

		Unit	CS-E12DKEW	CU-E12DKE	
Dimensions	Height	inch (mm)	11 - 1/32 (280)	21 - 1/4 (540)	
	Width	inch (mm)	31 - 15/32 (799)	30 - 23/32 (780)	
	Depth	inch (mm)	7 - 7/32 (183)	11 - 3/8 (289)	
Net Weight		lb (kg)	20 (9.0)	82 (37)	
Compressor	Type		—	Hermetic Rotary	
	Motor Type		—	Brushless (6-pole)	
	Rated Output	W	—	700	
Air Circulation	Type		Cross-flow Fan	Propeller Fan	
	Material		ASG20k1	P.P	
	Motor Type		Transistor (8-poles)	Induction (6-poles)	
	Input	W	—	65.9	
	Rate Output	W	30	29	
	Fan Speed	Lo (Cool/Heat)	rpm	910/1,080	—
		Me (Cool/Heat)	rpm	1,165/1,290	—
		Hi (Cool/Heat)	rpm	1,420/1,500	830
SHi (Cool/Heat)		rpm	1,460/1,540	—	
Heat Exchanger	Description		Evaporator	Condenser	
	Tube material		Copper	Copper	
	Fin material		Aluminium (Pre Coat)	Aluminium	
	Fin Type		Slit Fin	Corrugated Fin	
	Row / Stage		(Plate fin configuration, forced draft)		
			2 / 15	2 / 24	
	FPI		21	17	
Size (W × H × L)	mm	610 × 315 × 25.4	718.4 × 504 × 36.4 689.8		
Refrigerant Control Device			—	Capillary Tube	
Refrigeration Oil		(cm <sup>3</sup> )	—	RB68A (320)	
Refrigerant (R410A)		g (oz)	—	980 (34.6)	
Thermostat			Electronic Control	—	
Protection Device			Electronic Control	Electronic Control	
Capillary Tube	Length	mm	—	C1, C2 ; 1,120, C3 ; 370	
	Flow Rate	l/min	—	C1, C2 ; 4.9, C3 ; 19.6	
	Inner Diameter	mm	—	C1, C2 ; 1.2, C3 ; 1.7	
Air Filter	Material		P.P.	—	
	Style		Honeycomb	—	
Fan Motor Capacitor		μF, VAC	—	2.0 μF, 440 VAC	
Compressor Capacitor		μF, VAC	—	65 μF, 350 VAC	

- Specifications are subject to change without notice for further improvement.

# 4 Dimensions

## 4.1. Indoor Unit & Remote Control

### 4.1.1. CS-E9DKEW CS-E12DKEW

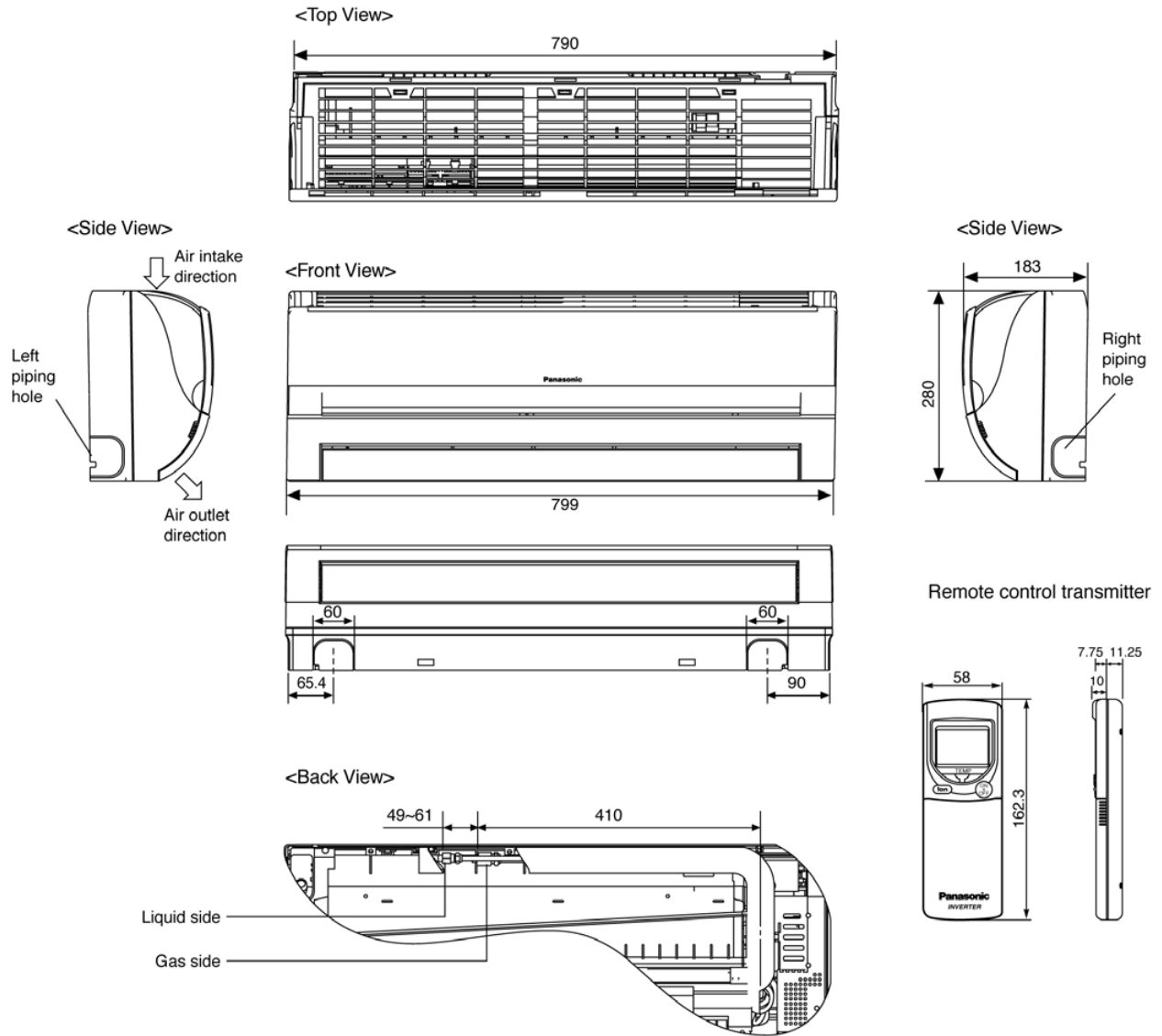

Relative position between the indoor unit and the installation plate <Front View>

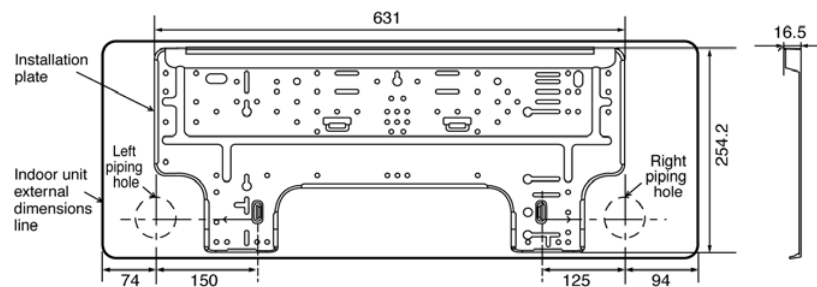

Unit : mm

## 4.2. Outdoor Unit

### 4.2.1. CU-E9DKE CU-E12DKE

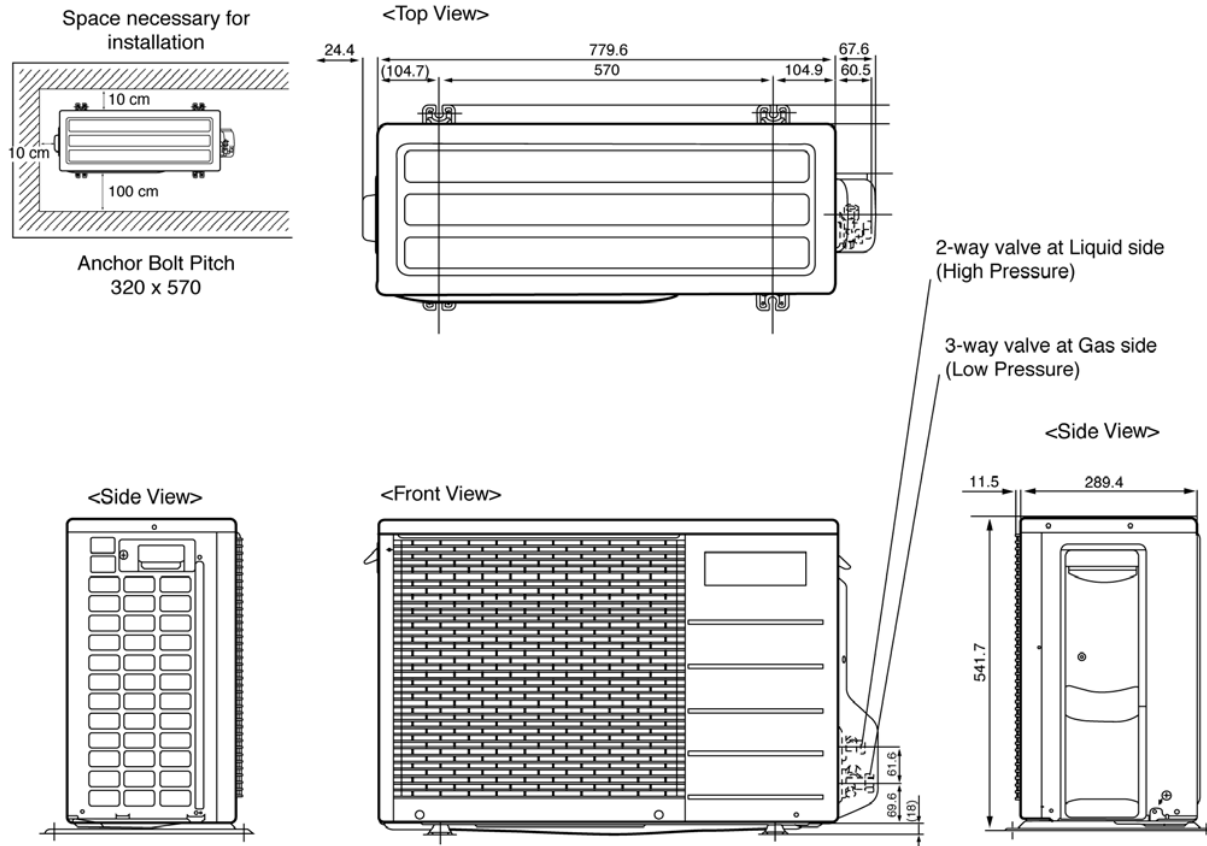

Unit:mm

# 5 Refrigeration Cycle Diagram

CS-E9DKEW CU-E9DKE  
 CS-E12DKEW CU-E12DKE

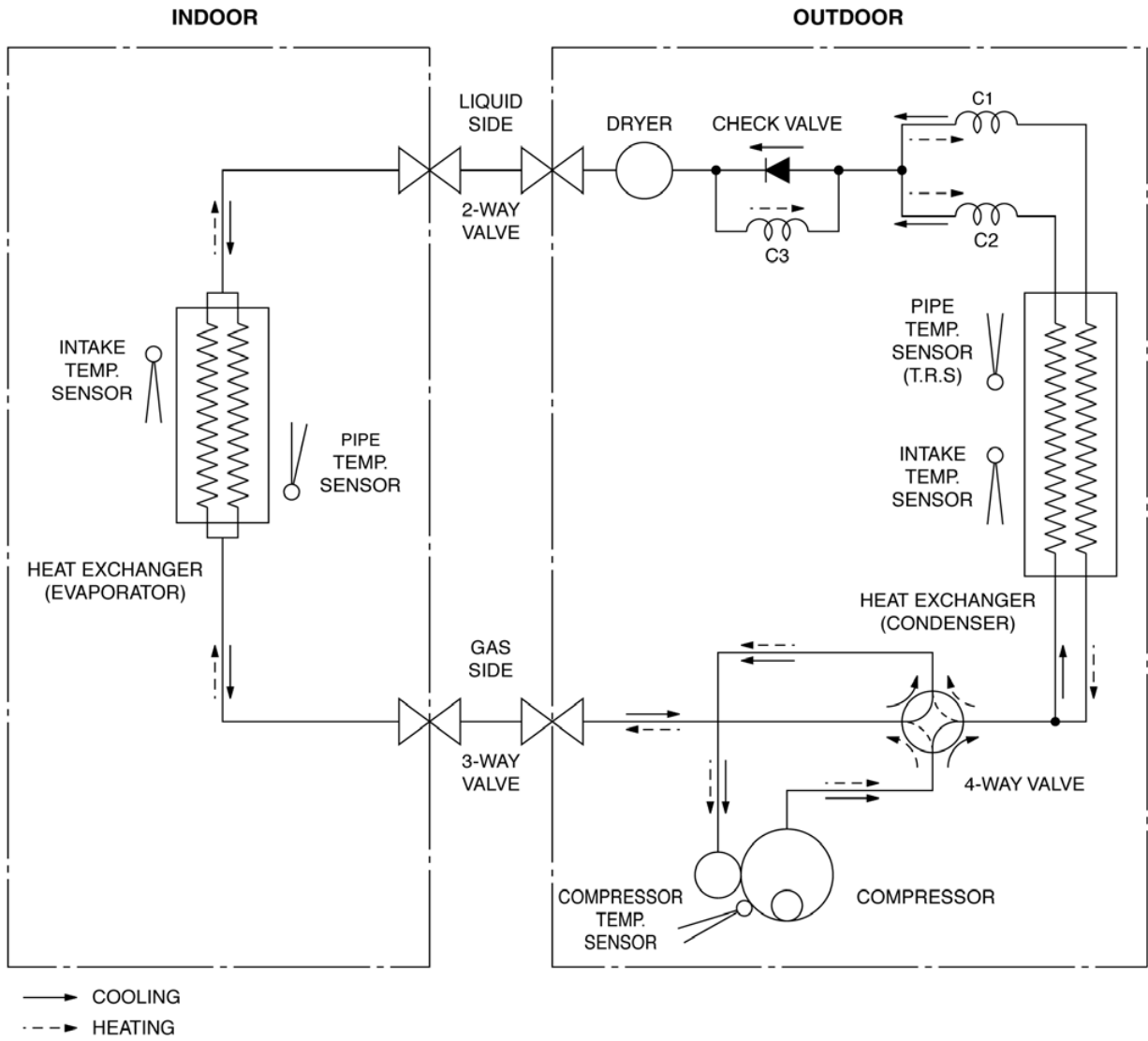

# 6 Block Diagram

CS-E9DKEW CU-E9DKE  
 CS-E12DKEW CU-E12DKE

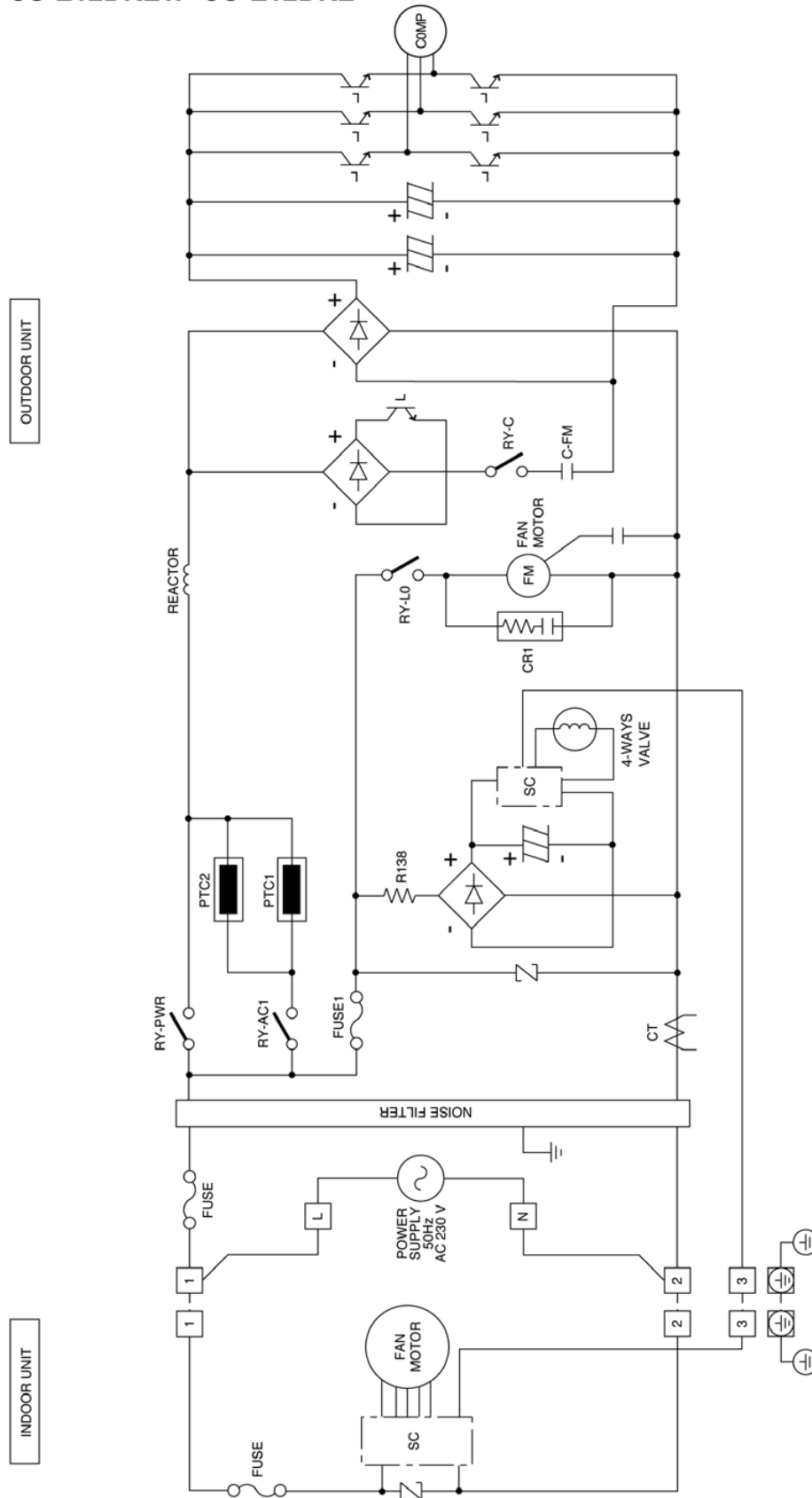

✳ [ ] Indicates the electronic control unit.

# 7 Wiring Diagram

CS-E9DKEW CU-E9DKE  
CS-E12DKEW CU-E12DKE

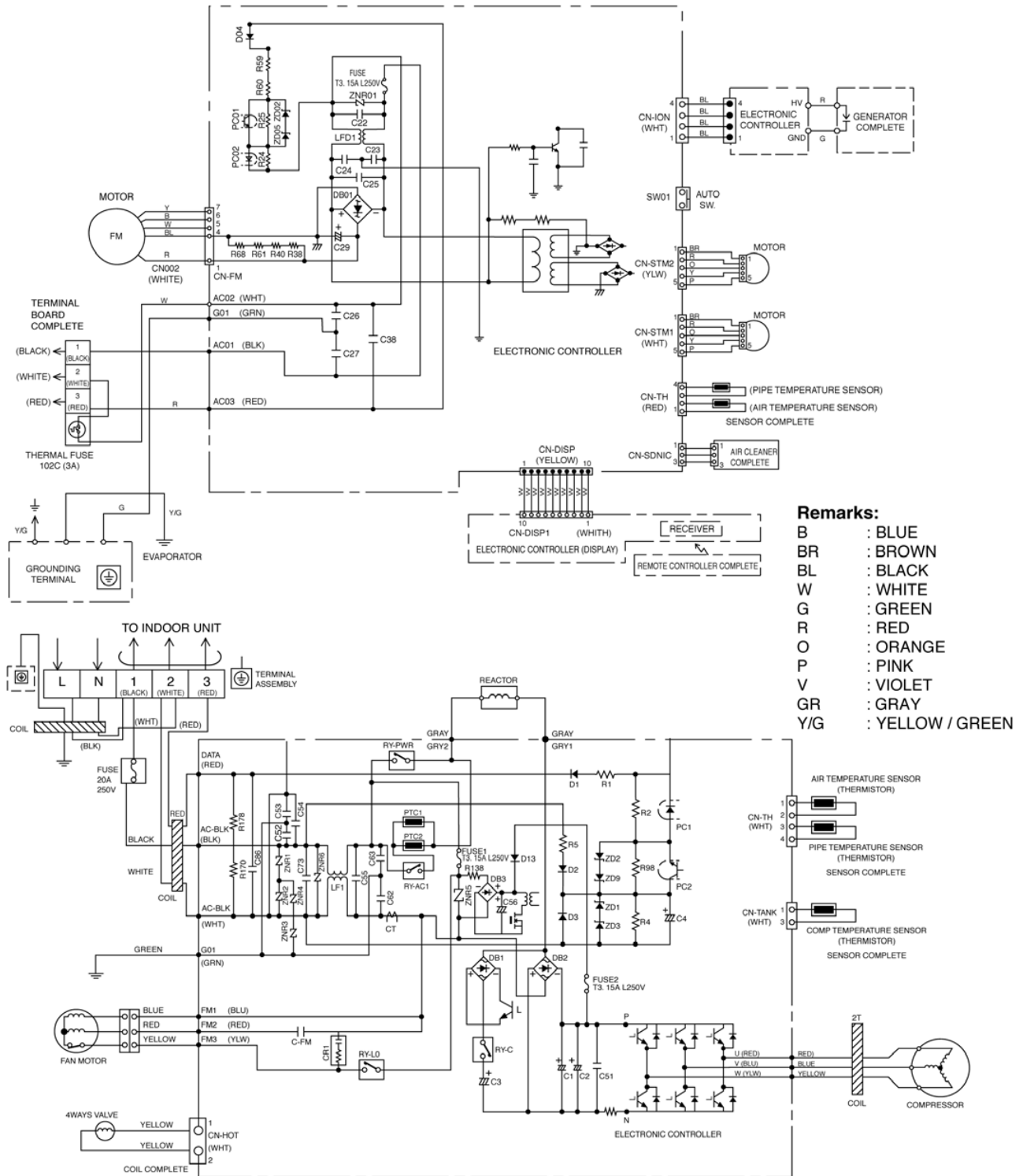



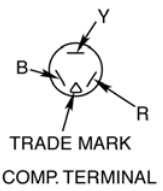





- Remarks:**
- B : BLUE
  - BR : BROWN
  - BL : BLACK
  - W : WHITE
  - G : GREEN
  - R : RED
  - O : ORANGE
  - P : PINK
  - V : VIOLET
  - GR : GRAY
  - Y/G : YELLOW / GREEN

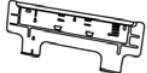

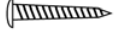
**Resistance of Compressor Windings**

CONNECTION	5RS102XBC01 (Ω)
U - V	0.858
U - W	0.858
V - W	0.858

**Attached accessories**

No.	Accessories part	Qty.	No.	Accessories part	Qty.
1	Installation plate 	1	5	Remote control holder 	1
2	Installation plate fixing screw 	6	6	Remote Control holder fixing screw 	2
3	Remote control 	1	7	Super alleru-buster filter 	1
4	Battery 	2	8	Drain elbow 	1

Applicable piping kit  
 CZ-3F5, 7BP (E9DK)  
 CZ-4F5, 7, 10BP (E12DK)

**SELECT THE BEST LOCATION**

**INDOOR UNIT**

- There should not be any heat source or steam near the unit.
- There should not be any obstacles blocking the air circulation.
- A place where air circulation in the room is good.
- A place where drainage can be easily done.
- A place where noise prevention is taken into consideration.
- Do not install the unit near the door way.
- Ensure the spaces indicated by arrows from the wall, ceiling, fence or other obstacles.
- Recommended installation height for indoor unit shall be at least 2.3 m.

**OUTDOOR UNIT**

- If an awning is built over the unit to prevent direct sunlight or rain, be careful that heat radiation from the condenser is not obstructed.
- There should not be any animal or plant which could be affected by hot air discharged.
- Keep the spaces indicated by arrows from wall, ceiling, fence or other obstacles.
- Do not place any obstacles which may cause a short circuit of the discharged air.
- If piping length is over the rated length, additional refrigerant should be added as shown in the table.

Model	Piping size		Rated Length (m)	Max. Elevation (m)	Max. Piping Length (m)	Additional Refrigerant (g/m)
	Gas	Liquid				
E9DK	3/8"	1/4"	7.5	5	15	20
E12DK	1/2"	1/4"	7.5	5	15	20

**Indoor/Outdoor Unit Installation Diagram**

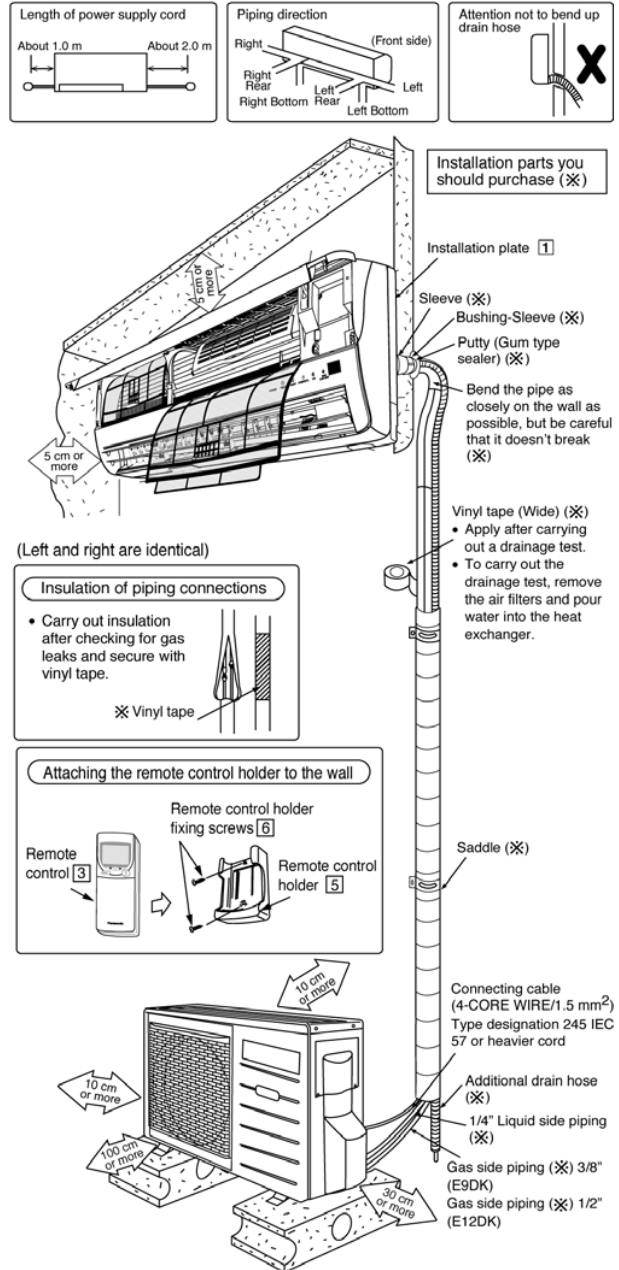

• This illustration is for explanation purposes only. The indoor unit will actually face a different way.

## 12 Servicing Information

### Caution:

- Pb free solder has a higher melting point than standard solder; Typically the melting point is 50 - 70°F (30 - 40°C) higher. Please use a high temperature soldering iron. In case of the soldering iron with temperature control, please set it to 700 ± 20°F (370 ± 10°C).
- Pb free solder will tend to splash when heated too high (about 1100° F/600°C).

### 12.1. Troubleshooting

#### 1. Rated Frequency Operation

During troubleshooting and servicing, rated compressor operating frequency must be obtained in order to check the specification and technical data. Below are the methods used to obtain rated compressor operating specification.

##### (a) Cooling

- Press the Auto button continuously for 5 seconds or less than 8 seconds, the air conditioner starts operation at Cooling rated frequency. ("beep" will be heard at the 5th second.)

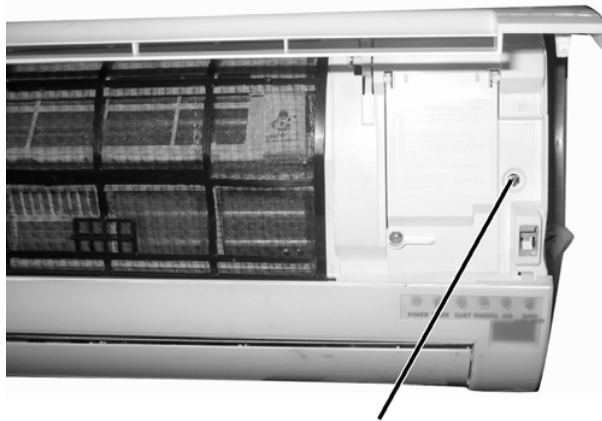

Automatic Operation Switch

- Short the service terminal (CN-S) of the outdoor printed circuit board. The operation of air conditioner is Cooling rated frequency.

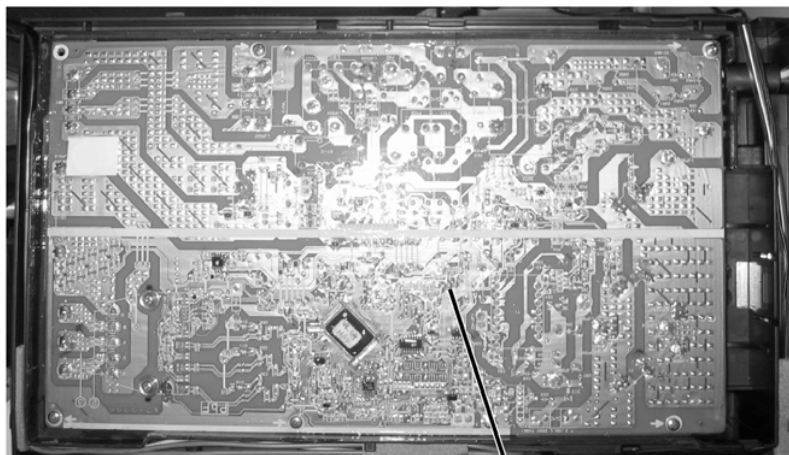

CN-S

##### (b) Heating

Press the Auto button continuously for 8 seconds or less than 11 seconds, the air conditioner starts operation at Heating rated frequency. ("beep" "beep" will be heard at the 8th second.)

**2. Troubleshooting Air Conditioner**

**Refrigeration cycle system**

In order to diagnose malfunctions, make sure that there are no electrical problems before inspecting the refrigeration cycle. Such problems include insufficient insulation, problem with the power source, malfunction of a compressor and a fan.

The normal outlet air temperature and pressure of the refrigeration cycle depends on various conditions, the standard values for them are shown in the table to the right.

Normal Pressure and Outlet Air Temperature (Standard)

	Gas pressure MPa (kg/cm <sup>2</sup> G)	Outlet air temperature (°C)
Cooling Mode	0.9 ~ 1.2 (9 ~ 12)	12 ~ 16
Heating Mode	2.3 ~ 2.9 (23 ~ 29)	36 ~ 45

- ★ Condition: • Indoor fan speed; High
- Outdoor temperature 35°C at cooling mode and 7°C at heating mode.
- Compressor operates at rated frequency

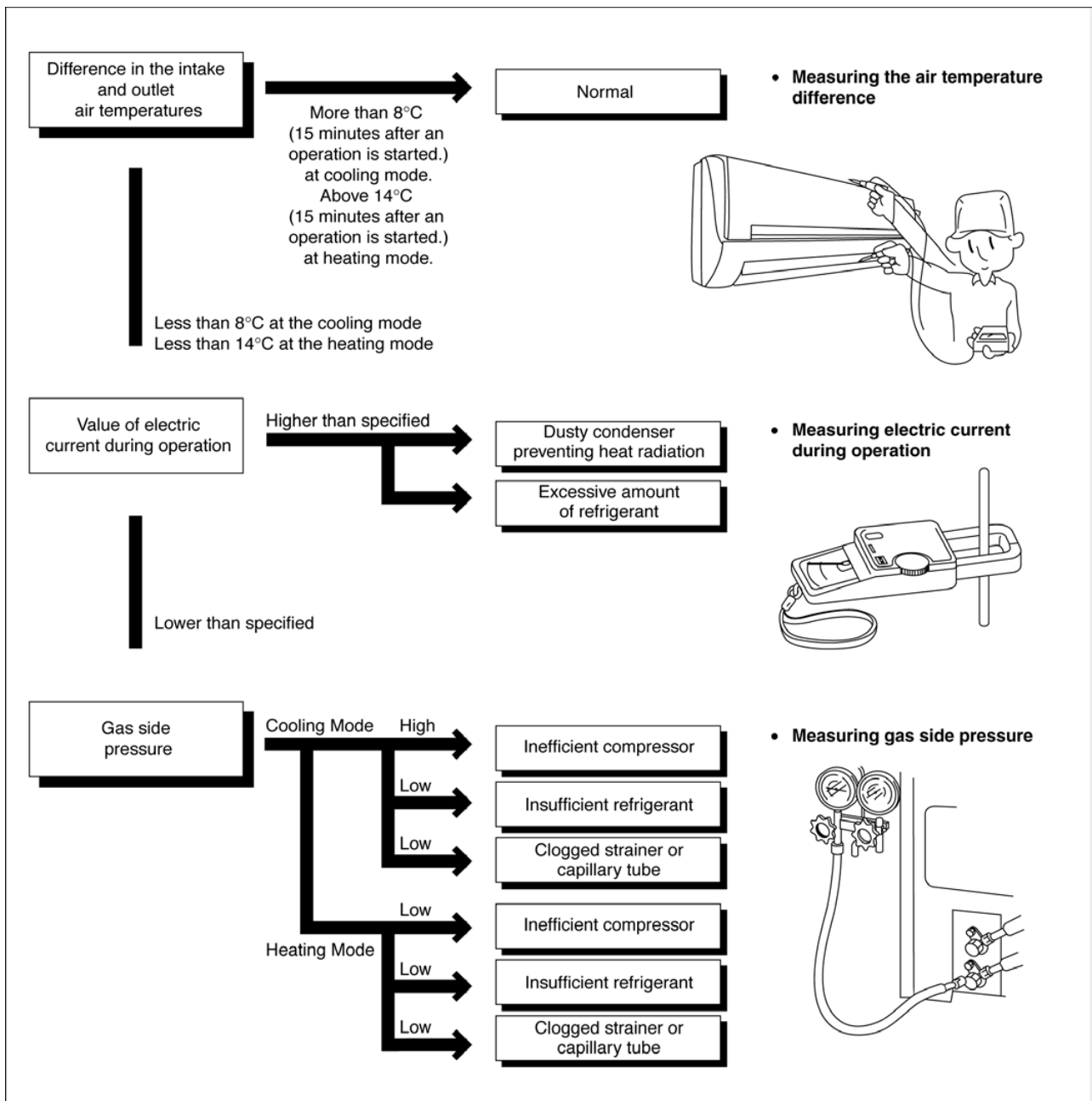

### 1. Relationship between the condition of the air conditioner and pressure and electric current

Condition of the air conditioner	Cooling Mode			Heating Mode		
	Low Pressure	High Pressure	Electric current during operation	Low Pressure	High Pressure	Electric current during operation
Insufficient refrigerant (gas leakage)	↘	↘	↘	↘	↘	↘
Clogged capillary tube or Strainer	↘	↘	↘	↗	↗	↗
Short circuit in the indoor unit	↘	↘	↘	↗	↗	↗
Heat radiation deficiency of the outdoor unit	↗	↗	↗	↘	↘	↘
Inefficient compression	↗	↘	↘	↗	↘	↘

- Carry on the measurements of pressure, electric current, and temperature fifteen minutes after an operation is started.

## 12.2. Breakdown Self Diagnosis Function

Once abnormality detected during operation, the unit will immediately stop its operation (Timer LED is blinking) and maximum of three error codes (abnormality) will be saved in memory. The abnormality of the operation can be identified through the below breakdown diagnosis method:

- Press "CHECK" button at remote controller continuously for more than five seconds to turn on the diagnosis mode, "H11" will be displayed at remote controller.
- By pressing the TMER "Λ" button once, next error code will be displayed; press "V" button once, previous error code will be displayed.
- If error code displayed matches the error code saved in unit memory (abnormality detected), "beep, beep, beep..." sounds will be heard for 4 seconds and Power LED will light on. Otherwise, one "beep" sound is heard.

If "CHECK" button is press again or without any operation for 30 seconds, the diagnosis mode will turn off.

Error Codes Table

Diagnosis display	Abnormality / Protection control	Abnormality Judgement	Emergency operation	Primary location to verify
H11	Indoor / outdoor abnormal communication	> 1 min after starting operation	Indoor fan operation only	<ul style="list-style-type: none"> <li>Internal / external cable connections</li> <li>Indoor / Outdoor PCB</li> </ul>
H12	Connection capability rank abnormal	—	—	—
H14	Indoor intake air temperature sensor abnormality	Continue for 5 sec.	—	<ul style="list-style-type: none"> <li>Intake air temperature sensor (detective or disconnected)</li> </ul>
H15	Outdoor compressor temperature sensor abnormality	Continue for 5 sec.	—	<ul style="list-style-type: none"> <li>Compressor temperature sensor (detective or disconnected)</li> </ul>
H16	Outdoor Current Transformer open circuit	—	—	<ul style="list-style-type: none"> <li>Outdoor PCB</li> <li>IPM (Power transistor) module</li> </ul>
H19	Indoor fan motor mechanism lock	—	—	<ul style="list-style-type: none"> <li>Indoor PCB</li> <li>Fan motor</li> </ul>
H23	Indoor heat exchanger temperature sensor abnormality	Continue for 5 sec.	O (Cooling only)	<ul style="list-style-type: none"> <li>Heat exchanger temperature sensor (detective or disconnected)</li> </ul>
H26	Ionizer breakdown	—	—	<ul style="list-style-type: none"> <li>Ionizer</li> </ul>
H27	Outdoor air temperature sensor abnormality	Continue for 5 sec.	O	<ul style="list-style-type: none"> <li>Outdoor temperature sensor (detective or disconnected)</li> </ul>
H28	Outdoor heat exchanger temperature sensor abnormality	Continue for 5 sec.	O	<ul style="list-style-type: none"> <li>Outdoor heat exchanger temperature sensor (detective or disconnected)</li> </ul>
H33	Indoor/Outdoor wrong connection	—	—	<ul style="list-style-type: none"> <li>Indoor/Outdoor supply voltage</li> </ul>
H38	Indoor / outdoor mismatch (brand code)	—	—	—
H98	Indoor high pressure protection	—	—	<ul style="list-style-type: none"> <li>Air filter dirty</li> <li>Air circulation short circuit</li> </ul>
H99	Indoor heat exchanger anti-freezing protection	—	—	<ul style="list-style-type: none"> <li>Insufficient refrigerant</li> <li>Air filter dirty</li> </ul>
F11	Cooling / Heating cycle changeover abnormality	4 times occurrence within 30 minutes	—	<ul style="list-style-type: none"> <li>4-way valve</li> <li>V-coil</li> </ul>
F90	PFC control	4 times occurrence within 10 minutes	—	<ul style="list-style-type: none"> <li>Voltage at PFC</li> </ul>
F91	Refrigeration cycle abnormality	2 times occurrence within 20 minutes	—	<ul style="list-style-type: none"> <li>No refrigerant (3-way valve is closed)</li> </ul>
F93	Compressor rotation failure	—	—	<ul style="list-style-type: none"> <li>Compressor</li> </ul>
F95	Cool high pressure protection	4 times occurrence within 20 minutes	—	<ul style="list-style-type: none"> <li>Outdoor refrigerant circuit</li> </ul>
F96	IPM (power transistor) overheating protection	—	—	<ul style="list-style-type: none"> <li>Excess refrigerant</li> <li>Improper heat radiation</li> <li>IPM (Power transistor)</li> </ul>
F97	Outdoor compressor overheating protection	4 times occurrence within 10 minutes	—	<ul style="list-style-type: none"> <li>Insufficient refrigerant</li> <li>Compressor</li> </ul>
F98	Total running current protection	3 times occurrence within 20 minutes	—	<ul style="list-style-type: none"> <li>Excess refrigerant</li> <li>Improper heat radiation</li> </ul>
F99	Outdoor Direct Current (DC) peak detection	7 times occurrence continuously	—	<ul style="list-style-type: none"> <li>Outdoor PCB</li> <li>IPM (Power transistor)</li> <li>Compressor</li> </ul>

Note:

“O” - Frequency measured and fan speed fixed.

The memory data of error code is erased when the power supply is cut off, or press the Auto Switch until “beep” sound heard following by pressing the “RESET” button at remote controller.

Although operation forced to stop when abnormality detected, emergency operation is possible for certain errors (refer to Error Codes Table) by using remote controller or Auto Switch at indoor unit. However, the remote controller signal receiving sound is changed from one “beep” to four “beep” sounds.

## 12.3. Remote Control

### • Remote Control Reset

When the batteries are inserted for the first time, or the batteries are replaced, all the indications will blink and the remote control might not work.

If this happen, remove the cover of the remote control and push the reset point once to clear the memory data.

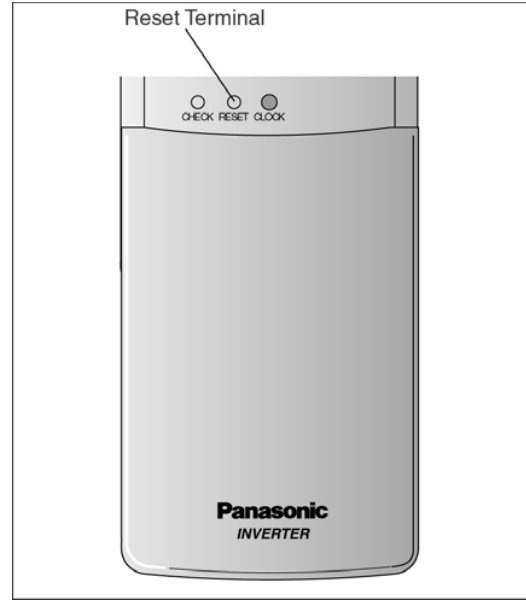

### • Changing the wireless remote control transmission code

When there are more than one indoor units installed in the same room, it is possible to set different remote control receiving signal by modifying the jumpers inside remote controller.

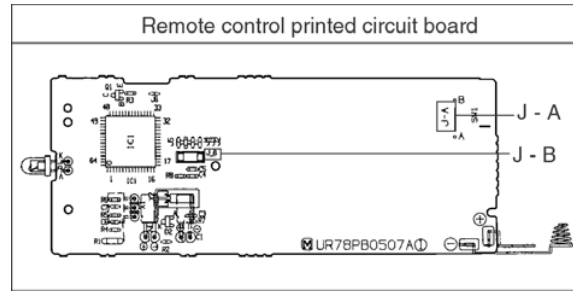

	Remote control printed circuit board		Note
	J - A	J - B	
0	SHORT	OPEN	At product delivery
1	OPEN	OPEN	
2	SHORT	SHORT	
3	OPEN	SHORT	

# 1 Technical Data (Page: 80 - 81)

## 1.1. Operation Characteristics

### 1.1.1. CS-E9DKEW CU-E9DKE

#### • Cooling Characteristic

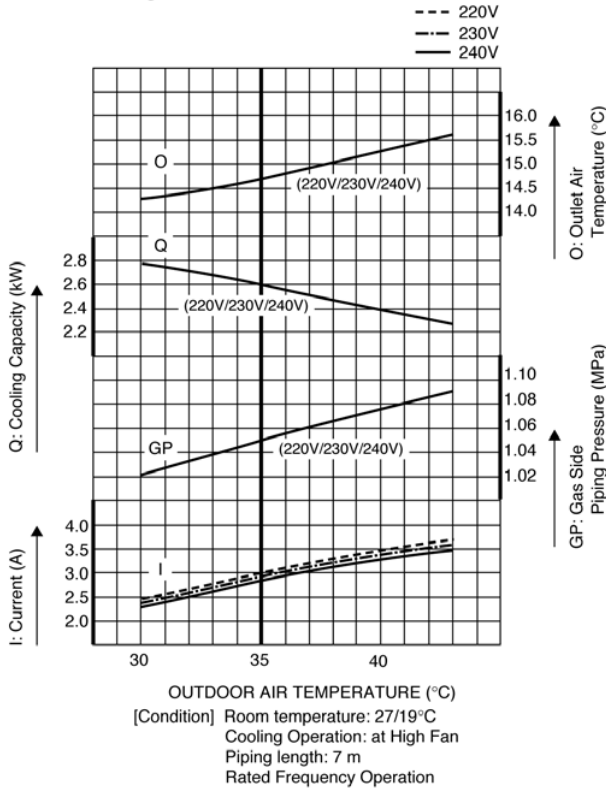

#### • Piping Length Characteristic (Cooling)

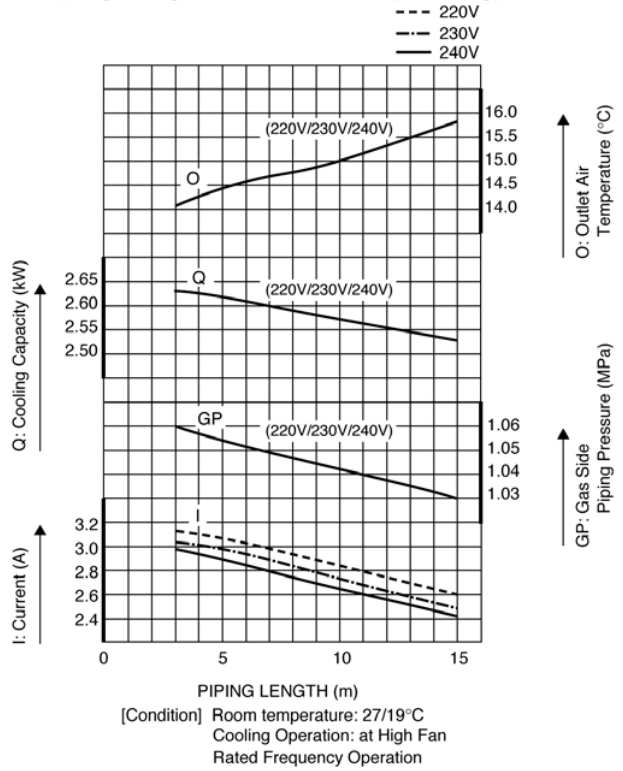

#### • Heating Characteristic

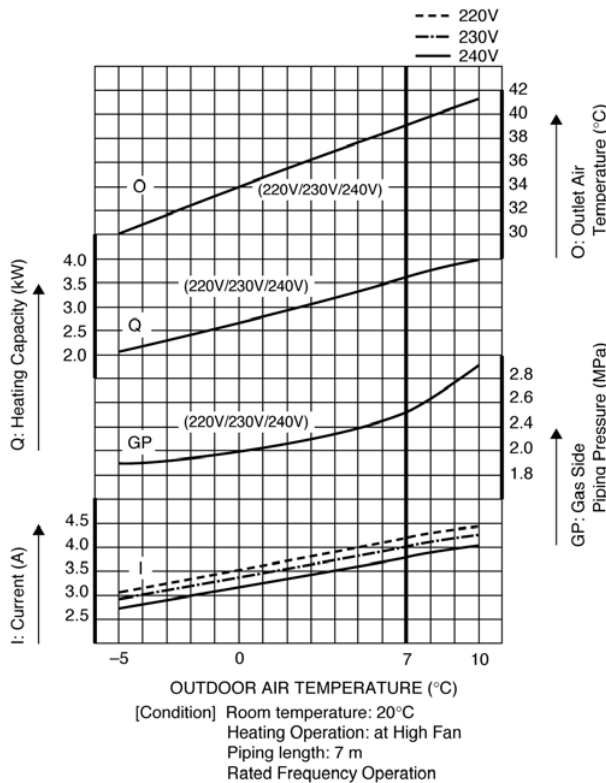

#### • Piping Length Characteristic (Heating)

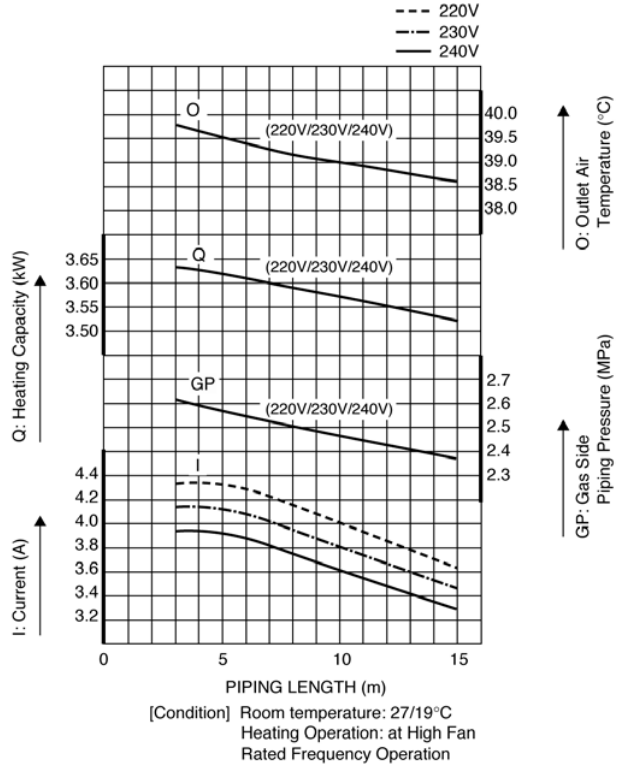

### 1.1.2. CS-E12DKEW CU-E12DKE

#### • Cooling Characteristic

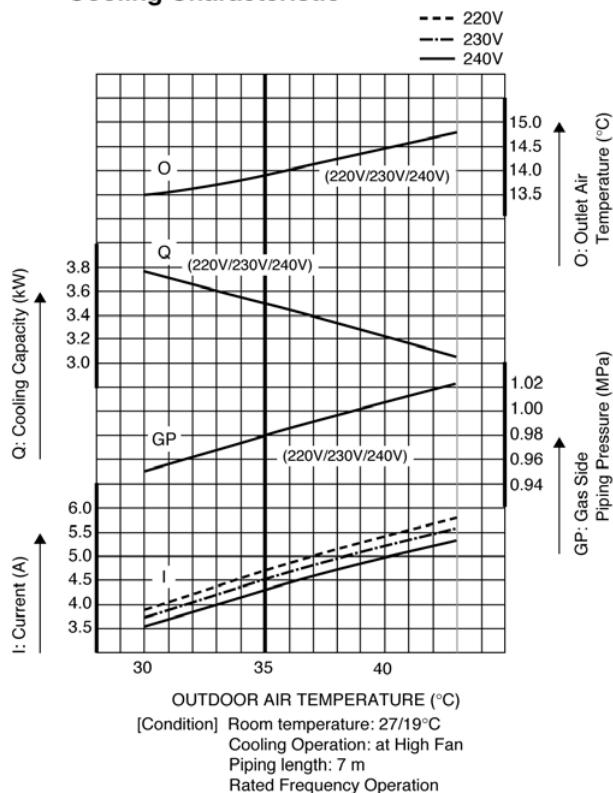

#### • Piping Length Characteristic (Cooling)

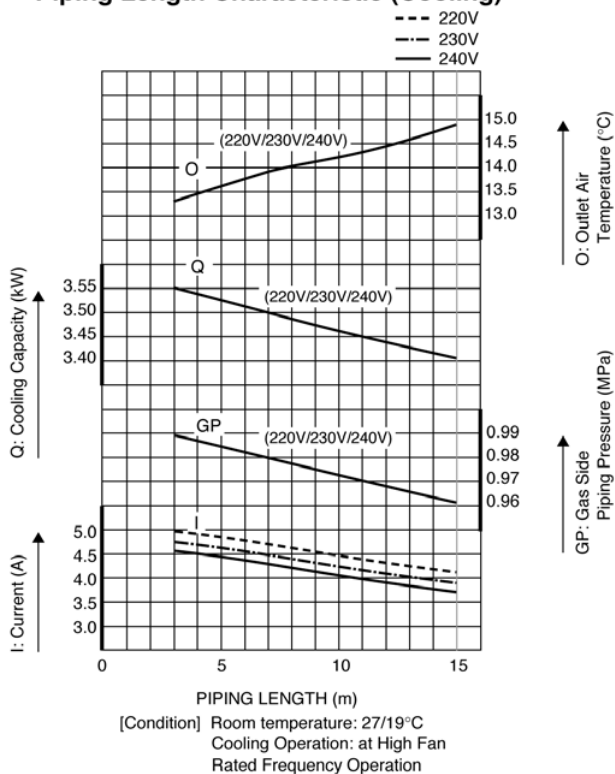

#### • Heating Characteristic

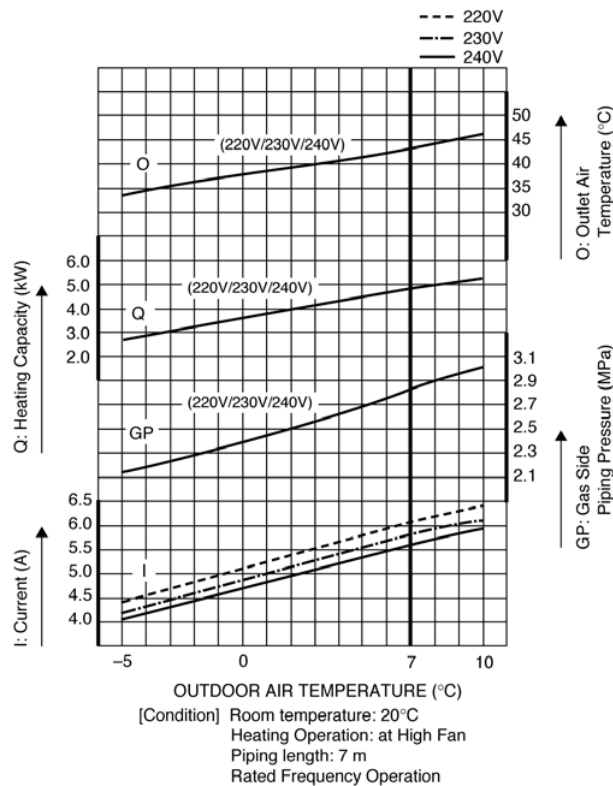

#### • Piping Length Characteristic (Heating)

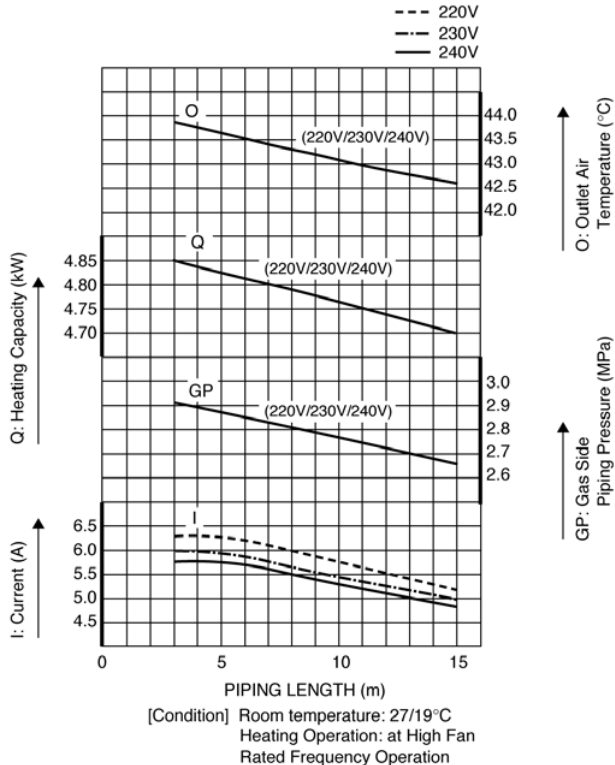

## 13.2. Sensible Capacity Chart

### ● CS-E9DKEW CU-E9DKE

230V Indoor wet bulb temp.	Outdoor Temp. (°C)											
	30			35			40			46		
	TC	SHC	IP	TC	SHC	IP	TC	SHC	IP	TC	SHC	IP
17.0°C	2.58	1.96	0.55	2.41	1.88	0.59	2.24	1.80	0.63	2.04	1.71	0.68
19.0°C				2.60		0.60						
19.5°C	2.83	2.05	0.56	2.65	1.97	0.60	2.46	1.89	0.64	2.24	1.80	0.69
22.0°C	3.09	2.12	0.57	2.88	2.04	0.61	2.68	1.97	0.66	2.44	1.88	0.71

### ● CS-E12DKEW CU-E12DKE

230V Indoor wet bulb temp.	Outdoor Temp. (°C)											
	30			35			40			46		
	TC	SHC	IP	TC	SHC	IP	TC	SHC	IP	TC	SHC	IP
17.0°C	3.47	2.63	0.88	3.24	2.52	0.95	3.02	2.43	1.02	2.74	2.30	1.10
19.0°C				3.50		0.97						
19.5°C	3.81	2.76	0.90	3.56	2.65	0.97	3.31	2.55	1.04	3.01	2.43	1.12
22.0°C	4.15	2.86	0.92	3.88	2.75	0.99	3.61	2.65	1.05	3.28	2.53	1.14

# 14 Exploded View (Indoor Unit)

## 14.1. CS-E9DKEW CS-E12DKEW

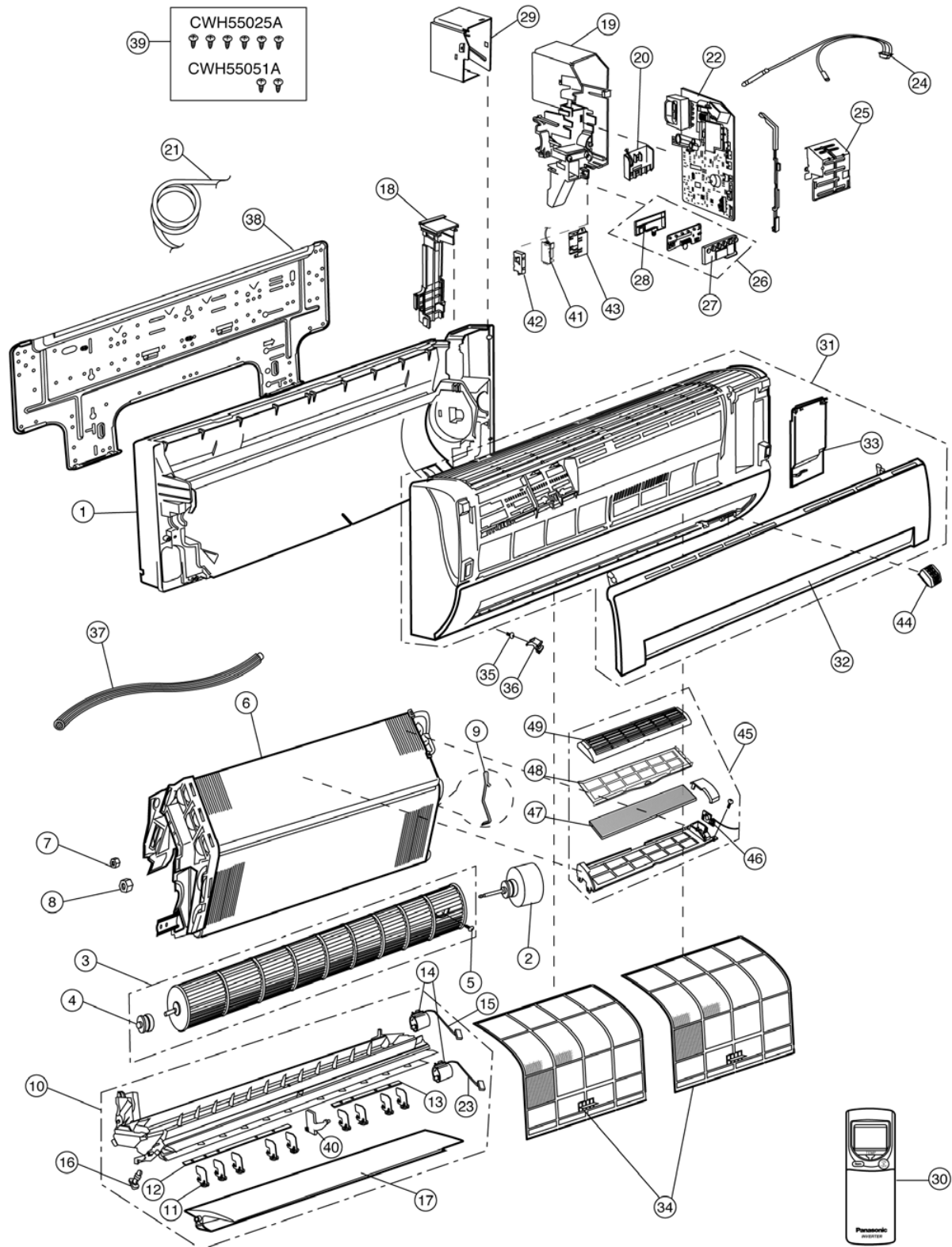

Note:

The above exploded view is for the purpose of parts disassembly and replacement.

The non-numbered parts are not kept as standard service parts.

# 15 Replacement Parts List (Indoor Unit)

## 15.1. CS-E9DKEW CS-E12DKEW

REF. NO.	PART NAME & DESCRIPTION	QTY.	CS-E9DKEW	CS-E12DKEW	REMARKS
1	CHASSY COMPLETE	1	CWD50C1431	←	
2	FAN MOTOR	1	CWA981149	←	0
3	CROSS FLOW FAN COMPLETE	1	CWH02C1031	←	
4	BEARING ASS'Y	1	CWH64K007	←	
5	SCREW - CROSS FLOW FAN	1	CWH4580304	←	
6	EVAPORATOR	1	CWB30C1597	CWB30C1726	
7	FLARE NUT	1	CWT25086 (1/4")	←	
8	FLARE NUT	1	CWT25087 (3/8")	CWT25096 (1/2")	
9	HOLDER SENSOR	1	CWH32143	←	
10	DISCHARGE GRILLE COMPLETE	1	CWE20C2343	←	
11	VERTICAL VANE	9	CWE241150	←	
12	CONNECTING BAR	1	CWE261072	←	
13	CONNECTING BAR	1	CWE261065	←	
14	AIR SWING MOTOR	2	CWA98260	←	0
15	LEAD WIRE - AIR SWING MOTOR	1	CWA67C3849	←	
16	CAP - DRAIN TRAY	1	CWH521096	←	
17	HORIZONTAL VANE	1	CWE241173	←	
18	BACK COVER CHASSIS	1	CWD932454	←	
19	CONTROL BOARD CASING	1	CWH102259	←	
20	TERMINAL BOARD COMPLETE	1	CWA28C2082	←	0
21	POWER SUPPLY CORD	1	-	-	
22	ELECTRONIC CONTROLLER - MAIN	1	CWA73C1667	CWA73C1668	0
23	LEAD WIRE - AIR SWING MOTOR	1	CWA67C3977	←	0
24	SENSOR COMPLETE	1	CWA50C2122	←	0
25	CONTROL BOARD FRONT COVER	1	CWH13C1120	←	
26	INDICATOR COMPLETE	1	CWE39C1126	←	0
27	INDICATOR HOLDER	1	CWD932429	←	
28	INDICATOR HOLDER	1	CWD932430	←	
29	CONTROL BOARD TOP COVER	1	CWH131207	←	
30	REMOTE CONTROL COMPLETE	1	CWA75C2616	←	0
31	FRONT GRILLE COMPLETE	1	CWE11C3138	←	0
32	INTAKE GRILLE	1	CWE22C1154	←	
33	GRILLE DOOR	1	CWE141073	←	
34	AIR FILTER	2	CWD001144	←	
35	SCREW - FRONT GRILLE	2	XTT4+16C	←	
36	CAP - FRONT GRILLE	2	CWH521109	←	
37	DRAIN HOSE	1	CWH851063	←	
38	INSTALLATION PLATE	1	CWH361067	←	
39	BAG COMPLETE - INSTALLATION SCREW	1	CWH82C067	←	
40	FULCRUM	1	CWH621046	←	
41	ELECTRONIC CONTROLLER - IONIZER	1	CWA743675	←	0
42	CASING - IONIZER	1	CWD932464	←	
43	CASING - IONIZER	1	CWD932431	←	
44	ION GENERATOR	1	CWH94C0001	←	
45	SUPERSONIC AIR PURIFYING DEVICE	1	CWH91C1013	←	
46	ELECTRONIC CONTROLLER SUPERSONIC	1	CWA743874	←	0
47	SUPER ALLERU BUSTER FILTER	1	CWD00C1133	←	
48	FRAME FR AIR FILTER SUPERSONIC	1	CWD011026	←	
49	FRAME FR AIR FILTER SUPERSONIC	1	CWD011027	←	

(Note)

- All parts are supplied from PHAAM, Malaysia (Vendor Code: 061).
- "O" marked parts are recommended to be kept in stock.

# 16 Exploded View (Outdoor Unit)

## 16.1. CU-E9DKE CU-E12DKE

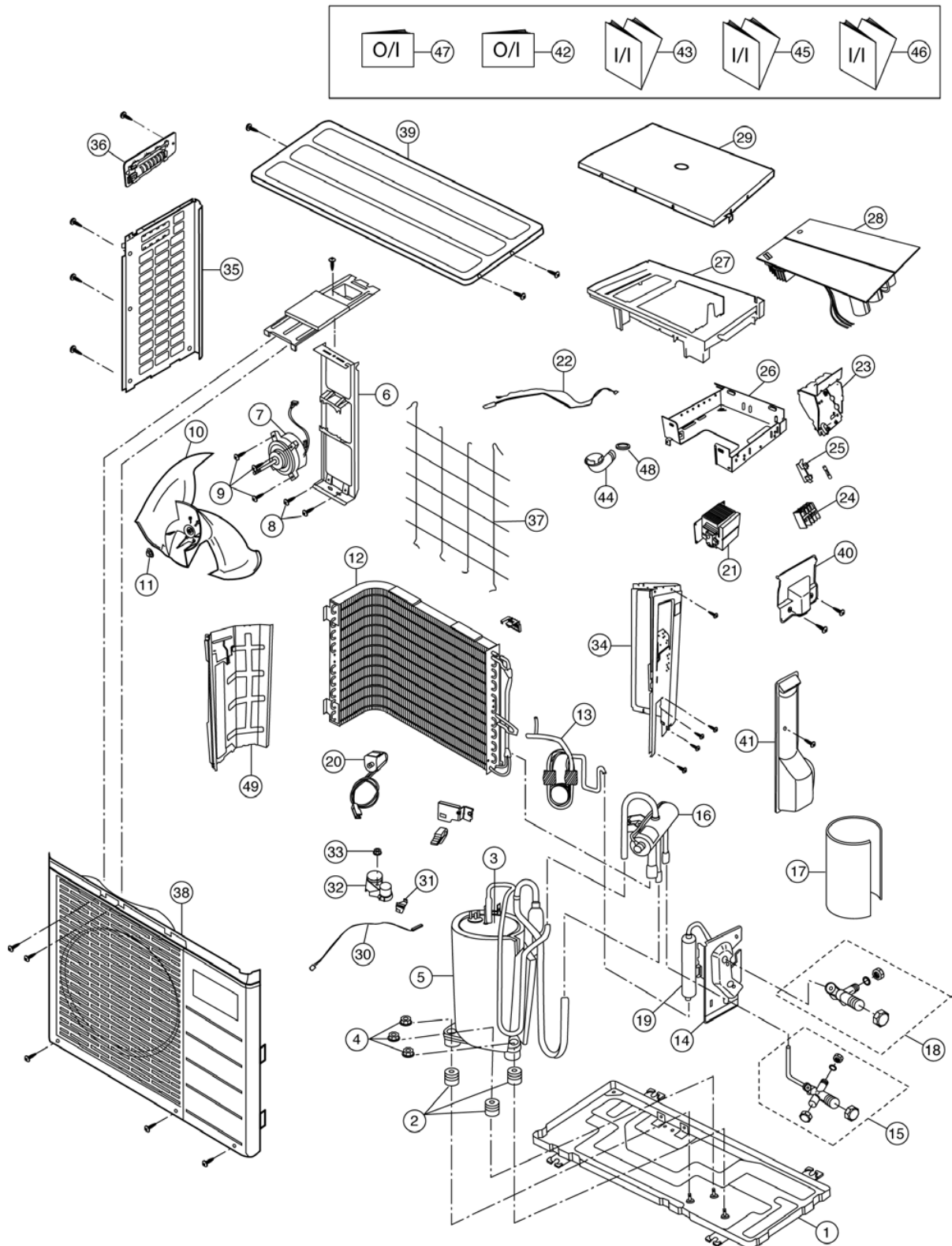

### Note:

The above exploded view is for the purpose of parts disassembly and replacement.

The non-numbered parts are not kept as standard service parts.

# 17 Replacement Parts List (Outdoor Unit)

## 17.1. CU-E9DKE CU-E12DKE

REF NO.	DESCRIPTION & NAME	QTY.	CU-E9DKE	CU-E12DKE	REMARKS
1	CHASSY ASSY	1	CWD50K2073	←	
2	ANTI-VIBRATION BUSHING	3	CWH50077	←	
3	COMPRESSOR	1	5RS102XBC01	←	O
4	NUT-COMPRESSOR MOUNT	3	CWH56000	←	
5	SOUND PROOF MATERIAL	1	CWG302293	←	
6	FAN MOTOR BRACKET	1	CWD541030	←	
7	FAN MOTOR	1	CWA951418	CWA951309	O
8	SCREW - FAN MOTOR BRACKET	2	CWH551060	←	
9	SCREW - FAN MOTOR MOUNT	4	CWH55406	←	
10	PROPELLER FAN ASSY	1	CWH03K1006	←	
11	NUT - PROPELLER FAN	1	CWH56053	←	
12	CONDENSER	1	CWB32C1560	CWB32C1599	
13	TUBE ASS'Y CO (CAP./CHK VALVE)	1	CWT01C3257	CWT01C3258	
14	HOLDER-COUPPLING COMPLETE	1	CWH351023	←	
15	3 WAYS VALVE	1	CWB011296	CWB011297	O
16	4 WAYS VALVE	1	CWB001037	←	O
17	SOUND PROOF MATERIAL	1	CWG302292	←	
18	2 WAYS VALVE	1	CWH021255	←	O
19	DRYER	1	CWB101017	←	O
20	V-COIL COMPLETE	1	CWA43C2143	←	O
21	REACTOR	1	CWA421050	-	
22	SENSOR COMPLETE	1	CWA50C2196	←	
23	CONTROL BOARD CASING	1	CWH102273	←	
24	TERMINAL BOARD ASSY	1	CWA28K1110	←	
25	FUSE HOLDERS	1	K5D203BBA002	←	
26	CONTROL BOARD	1	CWH102114	←	
27	CONTROL BOARD	1	CWH102115	←	
28	ELECTRONIC CONTROLLER	1	CWA73C1672R	CWA73C1673R	O
29	CONTROL BOARD COVER	1	CWH131104	←	
30	SENSOR COMPLETE	1	CWA50C2066	←	
31	HOLDER SENSOR	1	CWH321010	←	
32	TERMINAL COVER	1	CWH171001	←	
33	NUT-TERMINAL COVER	1	CWH7080300	←	
34	CABINET SIDE PLATE CO.	1	CWE04C1011	←	
35	CABINET SIDE PLATE (LEFT)	1	CWE041031A	←	
36	HANDLE	1	CWE161010	←	
37	WIRE NET	1	CWD041054A	←	
38	CABINET FRONT PLATE CO.	1	CWE06C1039	←	
39	CABINET TOP PLATE	1	CWE031014A	←	
40	CONTROL BOARD COVER	1	CWH131110	←	
41	CONTROL BOARD COVER	1	CWH131093	←	
42	OPERATING INSTRUCTION (ENG., ESP., ITA., NED., POR., GRE., BUL.)	1	CWF564451	←	
43	INSTALLATION INSTRUCTION (ENG., ESP., FRA., DEU.)	1	CWF612674	←	
44	L-TUBE	1	CWH5850080	←	
45	INSTALLATION INSTRUCTION (NED., GRE., ITA., POR.)	1	CWF612675	←	
46	INSTALLATION INSTRUCTION (BUL.)	1	CWF612676	←	
47	OPERATING INSTRUCTION (FRA., DEU., SWE., NOR.)	1	CWF564445	←	
48	PACKING-L.TUBE	1	CWB81012	←	
49	SOUND PROOF BOARD	1	CWH151025	←	

(Note)

- All parts are supplied from PHAAM Malaysia (Vendor Code: 061).
- "O" marked parts are recommended to be kept in stock.

### CS-E9DKEW CS-E12DKEW

Fig. 1

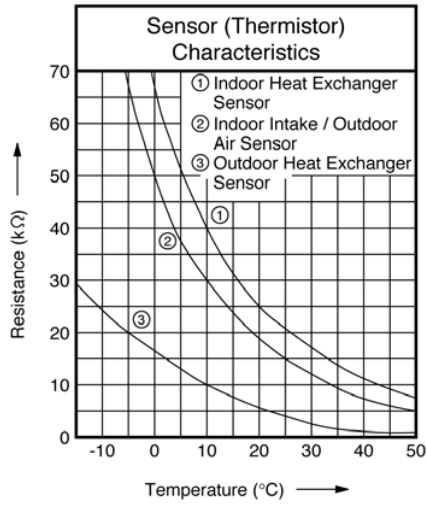
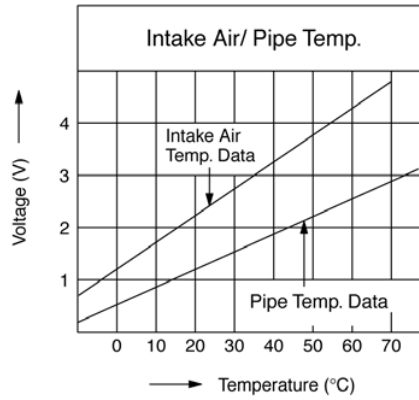

Fig. 2



### CU-E9DKE CU-E12DKE

Fig. 3

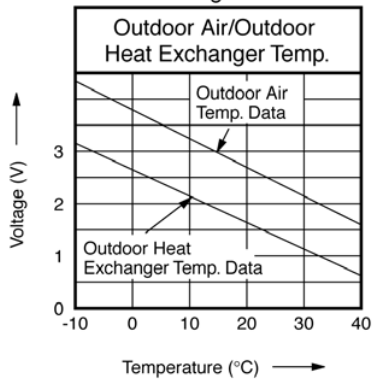

Fig. 4

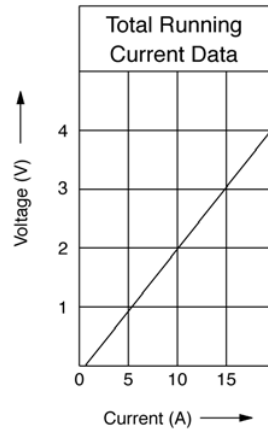

Fig. 5

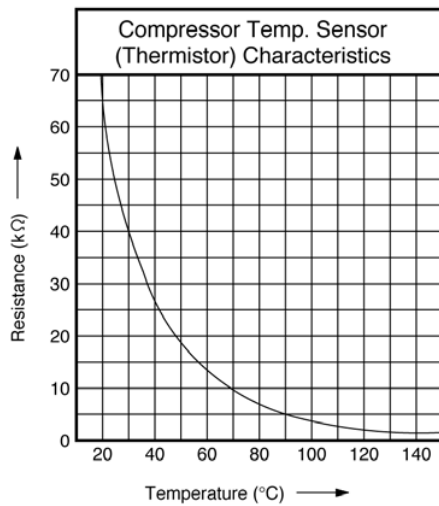

Fig. 6

